

# Installation Instructions - Live-Shaft Hold-Down Roller

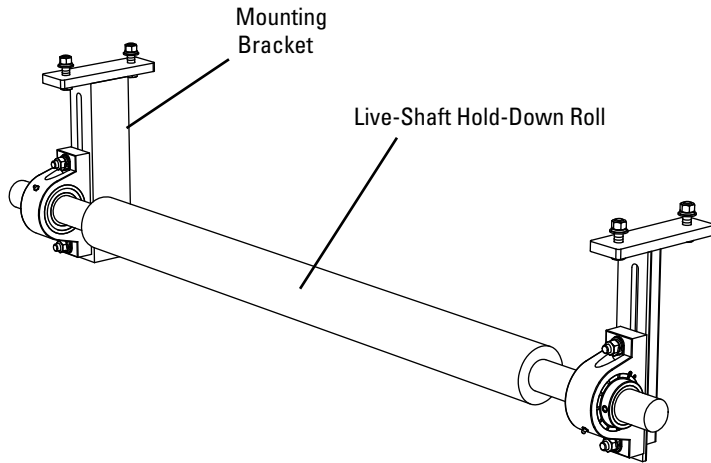

## Tools Needed:

- Tape measure
- 15/16" wrench (all roller sizes)
- 1-1/8" wrench (72" and 84" rollers)
- Crescent wrench
- C-clamps

**Physically lock out and tag the conveyor at the power source before you begin cleaner installation.**

**CAUTION: Components may be heavy. Use safety-approved lifting procedures.**

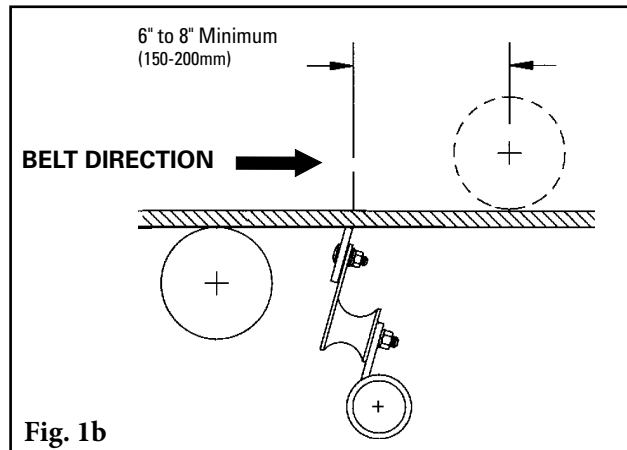
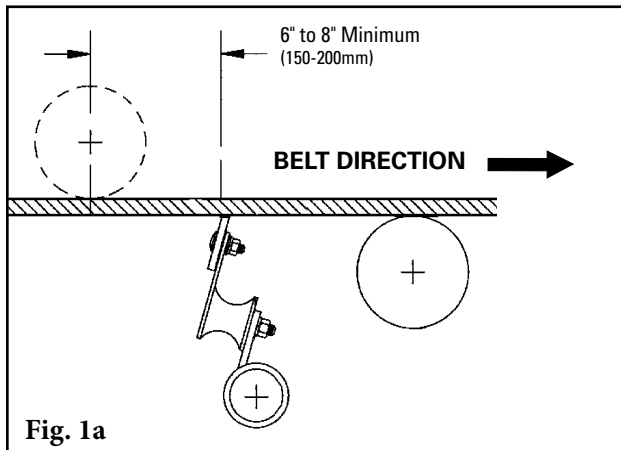

1. **Select best location:** Find location either in front or behind the belt cleaner 6" to 8" (150-200mm) (Fig. 1a and 1b). Also keep 6" to 8" (150-200mm) away from return rollers.

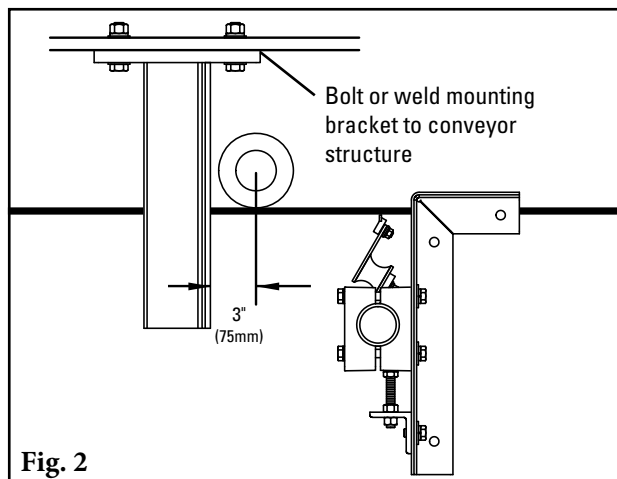

2. **Locate the position for the mounting brackets.** The position of the mounting brackets can vary slightly depending on the diameter of the live-shaft hold-down roller. As a rule of thumb, position the front of the mounting bracket 3" (75mm) past the contact point where the roller will meet the belt (Fig 2). Ensure there is enough length in the bracket slot to allow the roller to flatten the belt. Use C-Clamps to hold the brackets in place, then bolt or weld to structure.

3. **Install the live shaft roller to the bracket.** Lay the roller over the belt and loosen the bearings setscrews. Slide the bearing down the shaft until both bearings align with the slots in the mounting brackets and loosely install the bolts. Center the roller on the belt, then tighten the setscrews on both bearings.

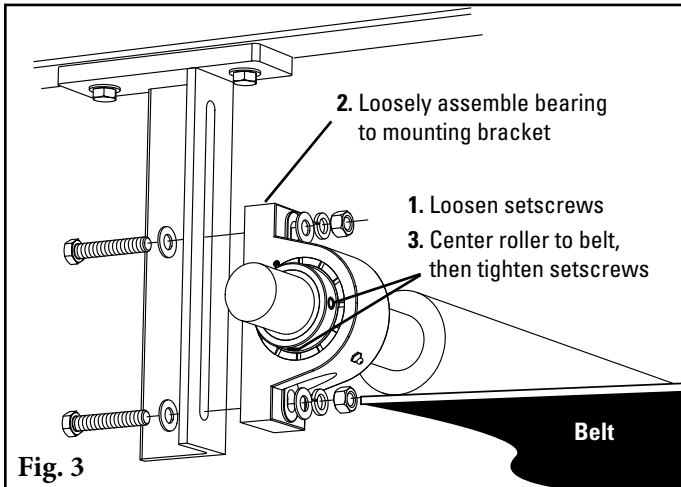

4. **Flatten the belt.** Apply downward pressure on the roller until the belt flattens. Tighten the bolts attaching the bearing to the mounting bracket (Fig. 4).

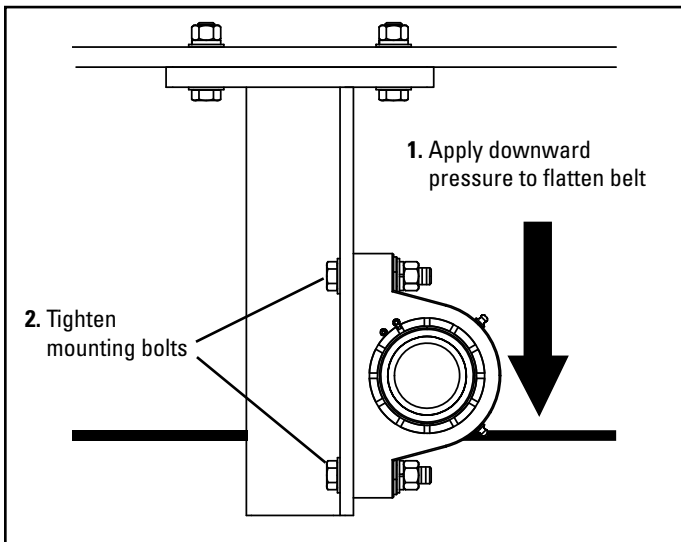

5. **Test run the roller and inspect performance.** Make adjustments as necessary.

1995 Oak Industrial Drive NE • Grand Rapids, MI 49505 • U.S.A.  
Tel: (616)-459-3196 • Fax: (616)-459-4976 • E-mail: info@flexco.com • Web: [www.flexco.com](http://www.flexco.com)

Australia: 61-2-8818-2000 • Chile: 56-2-8967870 • China: 86-21-33528388  
England: 44-1274-600-942 • Germany: 49-7428-9406-0 • India: 91-44-4354-2091  
Mexico: 52-55-5674-5326 • Singapore: 65-6281-7278 • South Africa: 27-11-608-4180

